

GReddy Turbo Kit

Acura RSX Type-S DC5 (K20A) T517Z 8cm²

Acura RSX Type-S DC5 (K20A) T517Z 8cm²

Installation Manual

Please read the entire manual before installing this kit.

Application:

Make	Model	Chassis	Year
Acura	RSX Type-S	DC5	02~03

- This **GReddy Turbo Kit** is designed only for the vehicles specified above.
- **GReddy Front mount intercooler kit** is recommended with this kit
- Premium grade gasoline (92 octane or higher) is required with this Kit.
- Make sure that the vehicle is not equipped with any ECU upgrade chips.
- Use of **GReddy Racing Spark Plugs ISO #7** or NGK plugs (colder than factory) is recommended with this kit.

Important

- This installation should only be performed by a trained specialist who is very familiar with the automobile's mechanical, electrical and fuel management system.
- If installed by an untrained person, it may cause damage to the kit as well as the vehicle.
- GReddy Performance Products Inc. is not responsible for any damage to the vehicle's electrical system caused by improper installation.

1. Parts List

1.	Turbocharger T517Z 8cm ² P565	1
2.	Turbo Exhaust Manifold (Cast Iron)	1
3.	Down Pipe Adapter (Cast Iron-Steel 60Ø)	1
4.	Suction Pipe (Aluminum 60Ø)	1
5.	TZ suction flange (Aluminum 60Ø)	1
6.	Compression Pipe C-1 (Aluminum 50Ø)	1
7.	“ C-2 (Aluminum 60Ø)	1
8.	“ C-3 (Aluminum elbow No. 76 60Ø)	1
9.	Restrictor (Aluminum 43Ø)	1
10.	Airinx AY-MB (Blue filter)	1
11.	Airinx Adapter (M60)	1
12.	Fuel Injector 440cc (w/spacerx2, stud bolt x2 o-ringx8)	4
13.	“ Connector Harness	4
14.	e-Manage	1
15.	I/J Harness (18P)	1
16.	Ignition Harness (12P)	1
17.	Sensor Adapter Type-All US	1
18.	Oil Pressure Hose SUS 600mm	1
19.	“ Banjo Fitting male & female (small)	1set
20.	“ Copper Washer 10Ø (t=1.0mm)	2
21.	“ Three Way Fitting	1
22.	“ Union Fitting 1/8PT – 1/8 PT	1
23.	“ Union Fitting 1/8PT – 1/8PF 90°	1
24.	Oil Return Flange tube 16Ø (Turbo side)	1
25.	“ Banjo Fitting male & female 16Ø (Engine side)	1Set
26.	“ Banjo Spacer t=16	1
27.	“ Banjo Copper washer 15.5Ø (t=1.0mm)	3

1. Parts List

28.	Vacuum Hose (Blue) 5Ø x 200mm	(for Actuator)	1
29.	Rubber Hose	8Ø X 500mm (for Idle controller)	1
30.	Rubber Hose	16Ø X 400mm (for Oil return)	1
31.	Rubber Hose	19Ø X 190mm (for Blow by)	1
32.	Silicone Hose	60Ø x70mm	2
33.	Reducer Hose	50Ø – 60Ø	1
34.	Reducer Hose	60Ø – 70Ø	1
35.	Hose band	8Ø Tridon #4	2
36.	Hose band	16Ø Tridon #10	2
36.	Hose band	19Ø Tridon #12	2
38.	Hose band	50Ø Tridon #32	1
39.	Hose band	60Ø Tridon #36	7
40.	Hose band	70Ø Tridon #44	1
41.	Gasket	Turbo in	2
42.	Gasket	Turbo out	1
43.	Gasket	Turbine in	1
44.	Gasket	Turbine out	1
45.	Gasket	Down Pipe	1
46.	Gasket	Oil Return Flange Tube Small	1
47.	Heat Shield	Turbine	1
48.	Heat Shield	Down pipe	1
49.	Thermo-cloth	100mm X 1000mm sheet	4
50.	Zip ties	150mm	10
51.	Zip ties	200mm	5
52.	Three-way Vacuum Tee	10Ø-6Ø-10Ø	1
53.	Suction pipe bracket		1
54.	Oil return hose bracket		1
55.	Airinx hose fitting	8Ø-M18	1
56.	Intake Air Temperature Grommet		1

1. Parts List

57.	M6 X 10	P=1.0	B S/W F/W	- (Down pipe heat shield)	2
58.	M6 X 15	P=1.0	B S/W F/W	- (Suction pipe & compression pipe bracket)	2
59.	M6 X 15	P=1.0	B S/W F/W N	(Suction pipe bracket)	1
60.	M6 X 15	P=1.0	B S/W	- - (Oil Return Bracket)	2
61.	M8 X 15	P=1.25	B S/W F/W	- (Turbine heat shield)	2
62.	M8 X 30	P=1.25	B S/W F/W N	(Compressor inlet)	2
63.	M8 X 20	P=1.25	B S/W F/W	- (Compressor outlet)	2
64.	M8 X 30	P=1.25	B S/W	- N (Exhaust manifold – Turbo in flange)	7
65.	M8 X 75	P=1.25	B S/W	- - (Turbine out)	2
66.	M8	P=1.25	- - -	N (Down pipe)	2
67.	M10 X 45	P=1.25	B S/W F/W N	(Ex. Manifold)	3

1. Parts List

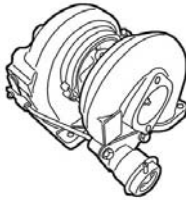

1



2

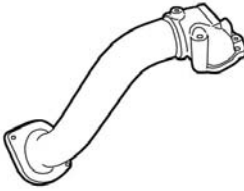

3

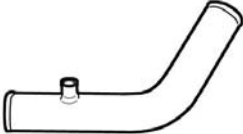

4



5

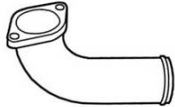

6

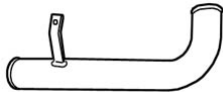

7

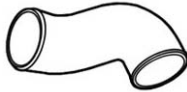

8



9



10

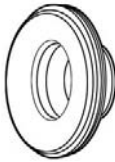

11



12

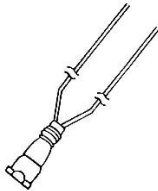

13



14



15-16



17



18

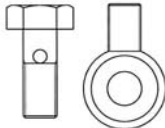

19



20

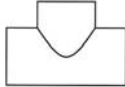

21

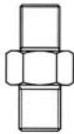

22

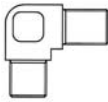

23



24

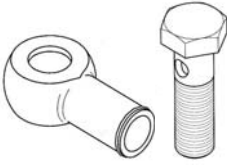

25

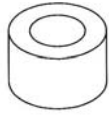

26

1. Parts List



27



28~31



32



33~34



35~40

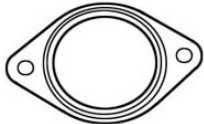

41

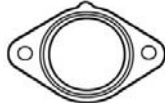

42

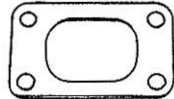

43



44



45



46

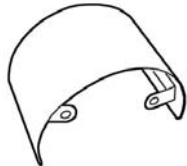

47

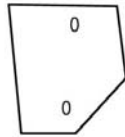

48

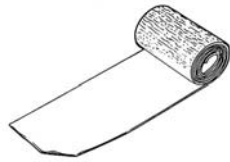

49



50~51



52

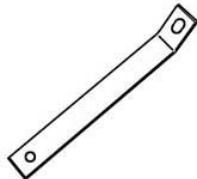

53



54



55



56

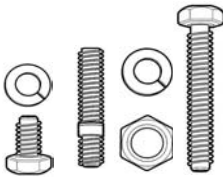

57~67

2. Removal of Stock Parts

When removing the stock parts, make sure you read over the factory repair manual for proper procedures.

- 2-1 Disconnect the negative terminal of the battery.
- 2-2 Release the fuel pressure in the fuel system by loosening the fuel pulsation damper on top of the fuel rail. (see factory repair manual for detail procedure).
- 2-3 Drain the engine oil.
- 2-4 Remove the front strut bar and it's brackets.
- 2-5 Remove the engine cover.
- 2-6 Remove the Air cleaner assembly with intake tube, breather hose and Intake temperature sensor.
- 2-7 Disconnect the primary and secondary O2 sensor and remover the catalytic converter.
- 2-8 Remove the VTEC solenoid valve assembly.
- 2-9 Remove the exhaust system heat shield and manifold.
- 2-10 Remove the heat shield plate (bottom of the firewall) and the intermediate drive shaft heat shield.

3. Kit Installation

3-1 Factory heat shield modification

- (1) Heat shield plate modification
Trim the shaded area on the heat shield plate that was removed as shown.

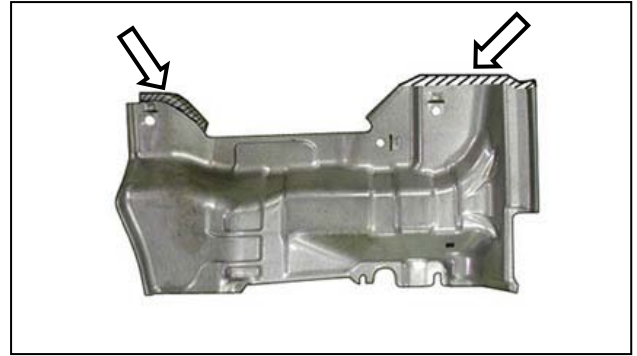

- (2) VTEC Solenoid Valve Assembly heat shield Modification.
Trim the shaded area on the heat shield that was removed as shown.

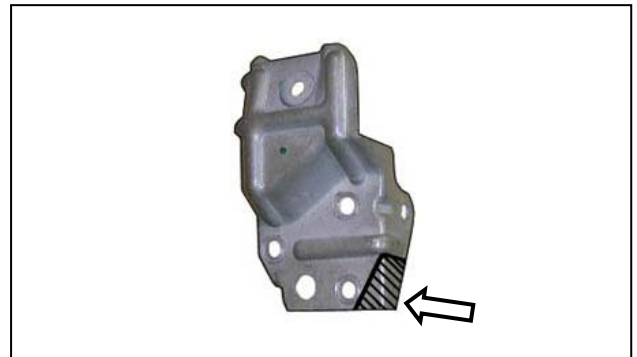

3-2 Thermo Cloth Installation

- (1) Disconnect the Crank sensor and Oil Pressure Sensor connector and wrap the thermo cloth to the harness as shown.
- (2) Wrap the thermo cloth to the power steering line by the fire wall.

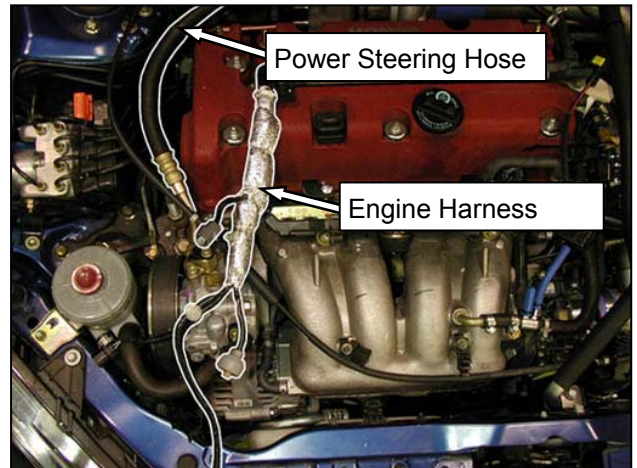

- (3) Wrap the thermo cloth to the engine harness and the heater hoses by the fire wall.



3-3 Power Steering Line Modification

Remove the power steering bracket off the line and valve cover. Bend the Power steering line so that the line routes closer towards the shock tower. Make sure not to kink or break the line.



3-4 Oil Pressure Line Installation

(1) Remove the Oil Pressure switch and install the union fitting and 3-way fitting on to the block.

* Use Teflon tape on the thread.

* Point the 3-way fitting outlet where the oil pressure switch is going to be installed to 2 o'clock.

(Parts used #21,22,23)

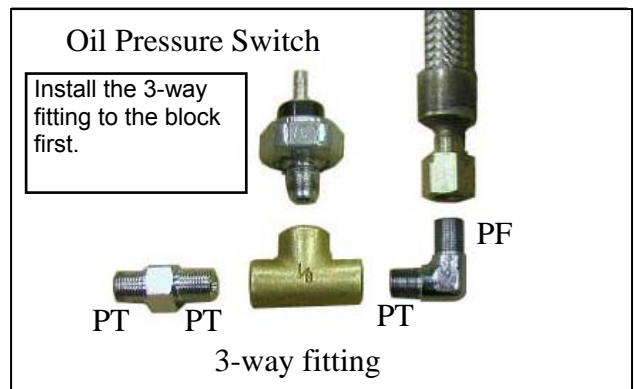

(2) Install the oil pressure switch to the 3-way fitting and reinstall the VTEC solenoid assembly with the modified heat shield.

* Make sure that the heat shield does not hit the oil pressure switch.

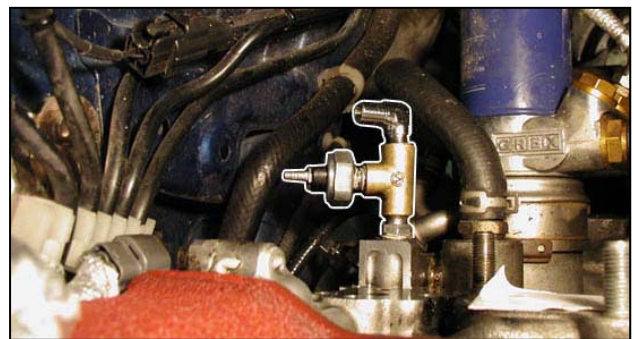

(3) Reconnect the oil pressure switch harness and the crank sensor.

(4) Connect the oil pressure line to the installed union fitting.

(Parts used #18)

